

## PLW 1003 - 1x3 LED video wall mount

EN Mounting instructions

DE Montageanleitung

FR Consignes d'installation

NL Montagevoorschrift

ES Instrucciones de montaje

IT Istruzioni di montaggio

PT Manual de montagem

EL Οδηγίες συναρμολόγησης

SV Montageföreskrifter

PL Instrukcja montażu

RU Инструкция по сборке и установке

CZE Návod k montáži

SK Návod na montáž

HU Szerelési előírás

TR Montaj kılavuzu

RO Instrucțiuni de montaj

UK Вказівки по монтажі

BG Инструкции за монтаж

JA 設置の説明書

ZH 装配说明

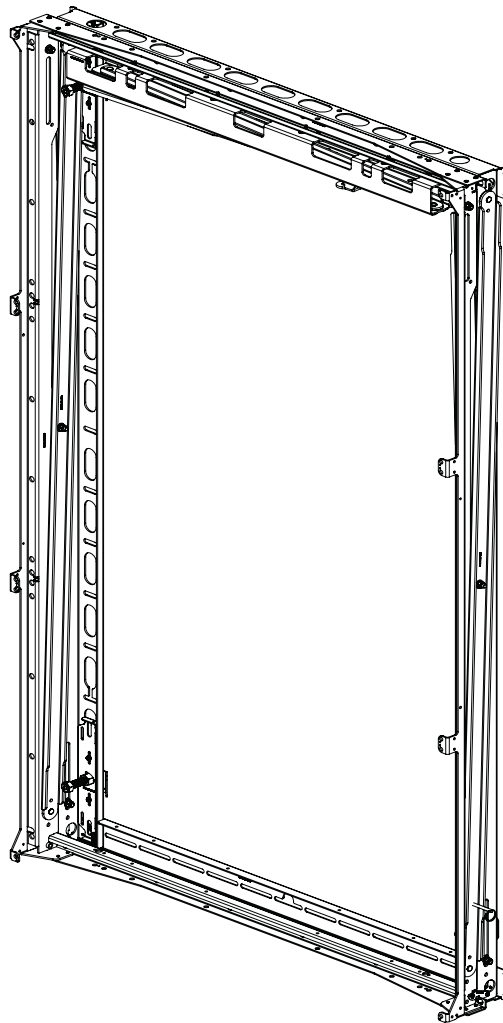

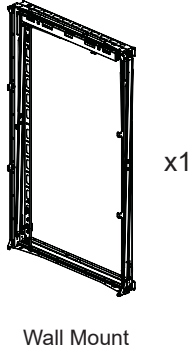

- A**  
 x4  
5/8"-10 x 2" Bolt with hole
- B**  
 x4  
5/16" x 6" Lag Bolt
- C**  
 x5  
5/16" Washer
- D**  
 x1  
5/16" x 3" Lag Bolt
- E**  
 x12  
M6 x 20mm Socket Cap
- F**  
 x1  
1/4" x 2 1/2" Push Pin
- G**  
 x1  
M5 Allen Key
- H**  
 x1  
M2 Allen Key
- I**  
 x4  
Wall Plate
- J**  
 x8  
M5 x 6 mm Flat Head Screw
- K**  
 x6  
M5 x 10 mm Screw
- L**  
 x12  
M4 x 6 mm Set Screw
- M**  
 x2  
Spacer Bracket
- N**  
 x4  
M6 x 16 mm Flat Socket Head
- O**  
 x2  
M8 x 70 mm Screw
- P**  
 x1  
5/32" Allen Key

1

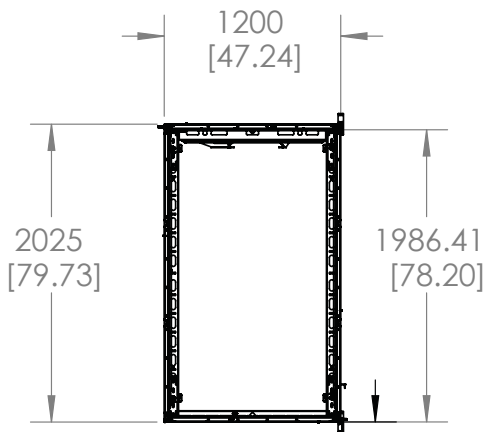

- 1) Find your desired mounting location.
- 2) Drill the 5/16" x 3" lag bolt (D) with washer (C) into the wall



Do not fully drill 5/16" x 3" lag bolt into the wall. Leave 25 mm [1" inch] out.

FOR SUPPORT SCREW LOCATION,  
DESIRED DISTANCE FROM  
FLOOR PLUS 1986.4 mm.

2

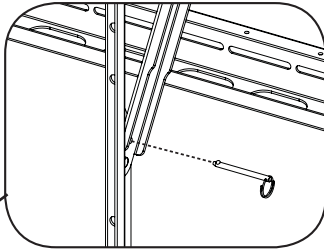
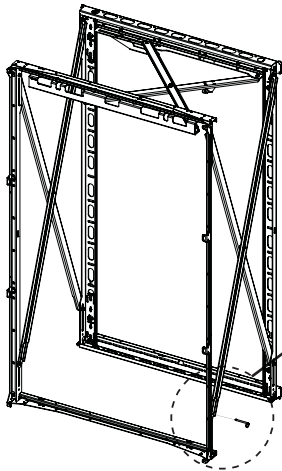

- 1) Extend the mount.
- 2) Install the 1/4" x 2 1/2" push pin (F) to keep the mount extended.

3

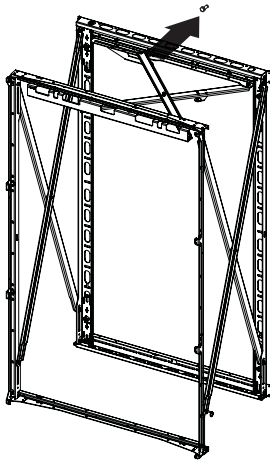

Key Slot

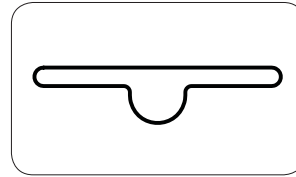

Place the wall mount over the lag bolt through the key slot hole.

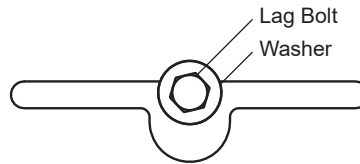

4

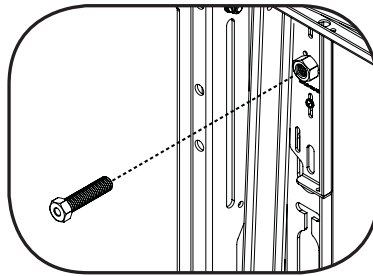
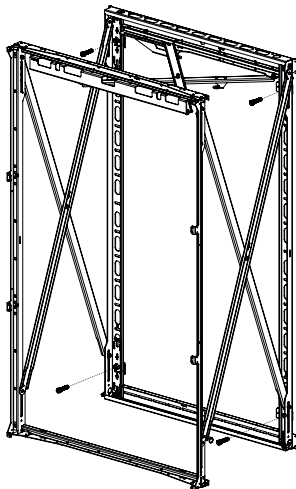

Flush Bolt

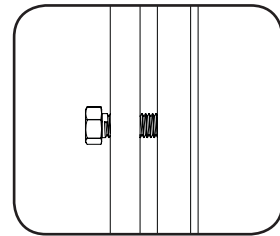

Install the four (4) 5/8"-10 x 2" Bolt (A) with hole into the wall mount. Flush all threads to edge.

5

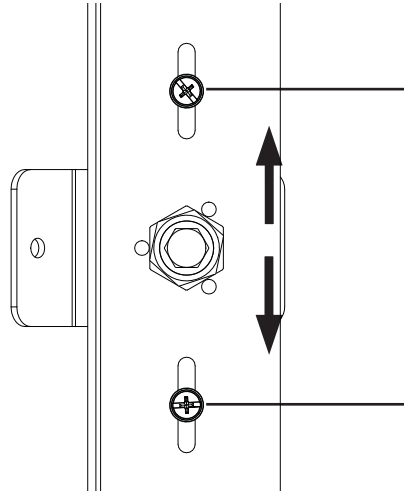
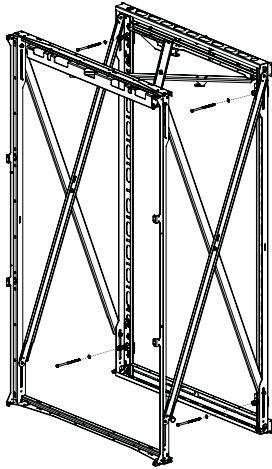

Before installing the 5/16" x 6" lag bolt and washer make sure the phillips screw is in the center of the slots. This will give 1/2" adjustments either up or down.

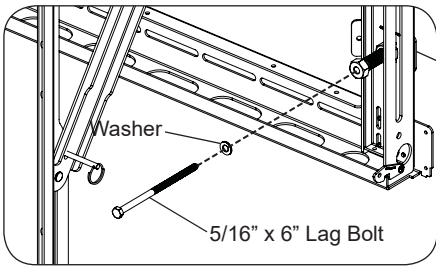

- 1) Level the wall mount.
- 2) Place the wall bracket (M) between the wall mount and wall.
- 3) Secure the mount into the wall using four (4) 5/16" x 6" lag bolts (B) and four (4) 5/16" washers (C) into the 5/8"-10" bolt (A) with hole.

## 6 Adjustments

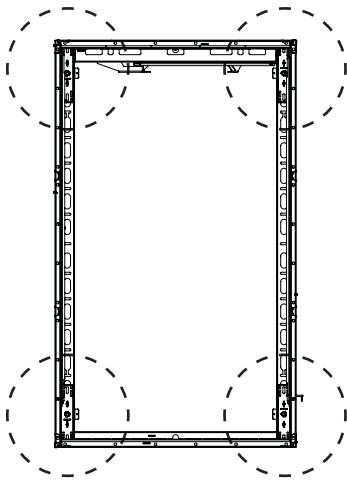

### In / Out

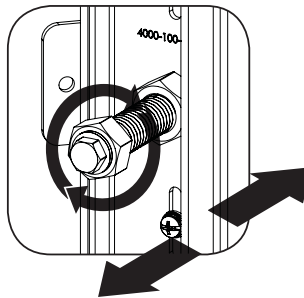

Uneven wall surfaces can be adjust by turning the 5/8"-10 x 2 Bolt (A) with hole.

### Up / Down

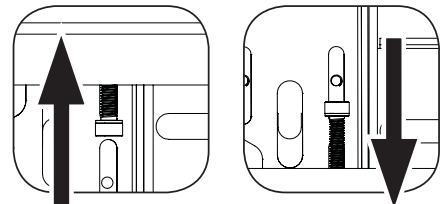



# 7

Note: If using the additional slots for mounting points, make sure that the floating frame is fully level to the wall vertically and horizontally. Must use shims (commercially available) on every slots being used to fill the void between the wall and the frame. Avoid over tightening the screws as this would make the floating frame uneven.

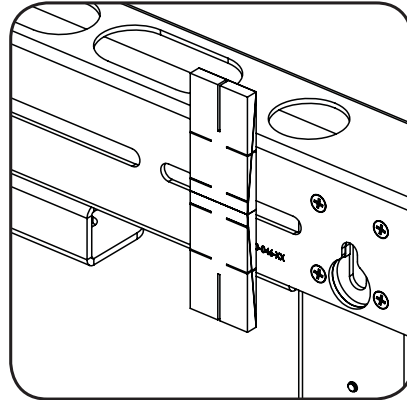
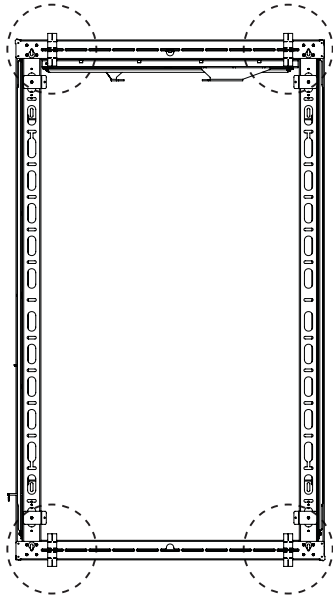

# 8

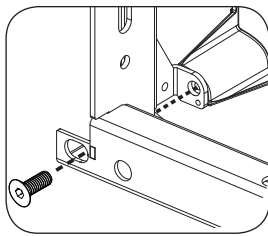
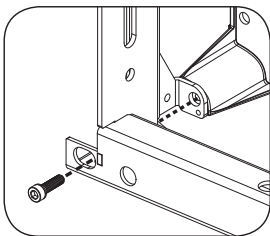
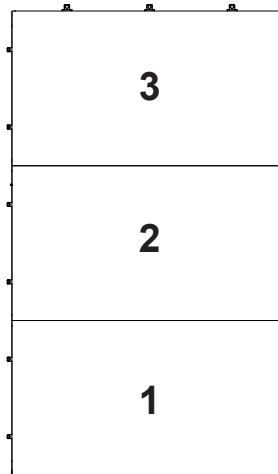
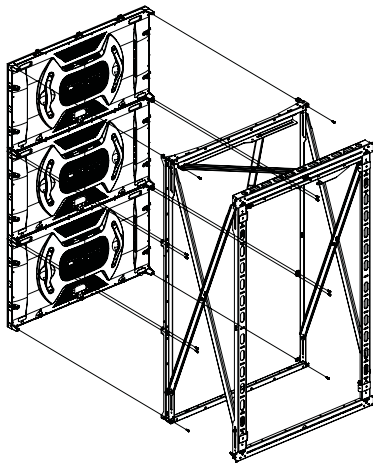

- 1) Use four (4) M6 x 16 mm flat socket head screws (N) on the first LED display to center it in place.
- 2) Install the second and third LED display using four (4) M6 x 20 mm socket cap screw in each LED display (E).
- 3) Optional to change the M6 x 16 mm flat socket head screws (N) to M6 x 20 mm socket cap screws E).
- 4) Install the LED panels in the following order as shown above.

9

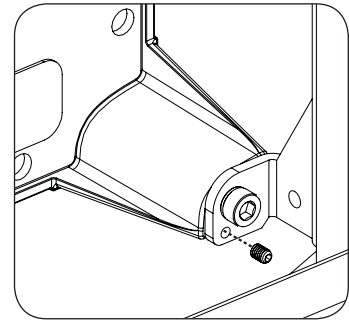
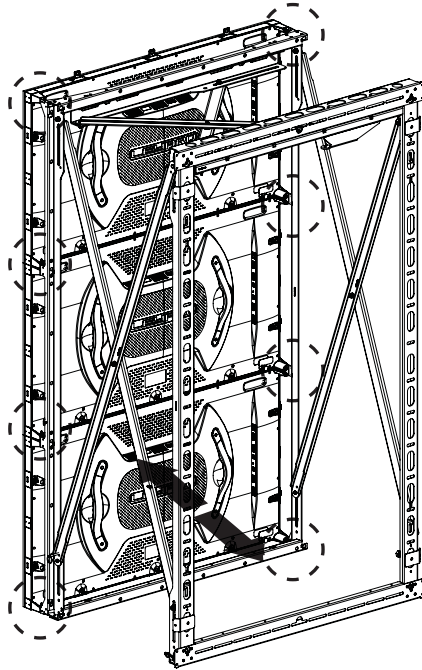

Install twelve (12) M4 x 6 mm set screws (L). You can adjust the panel in & out by using the M2 Allen key (H).

### OPTIONAL EXTENSIONS

10

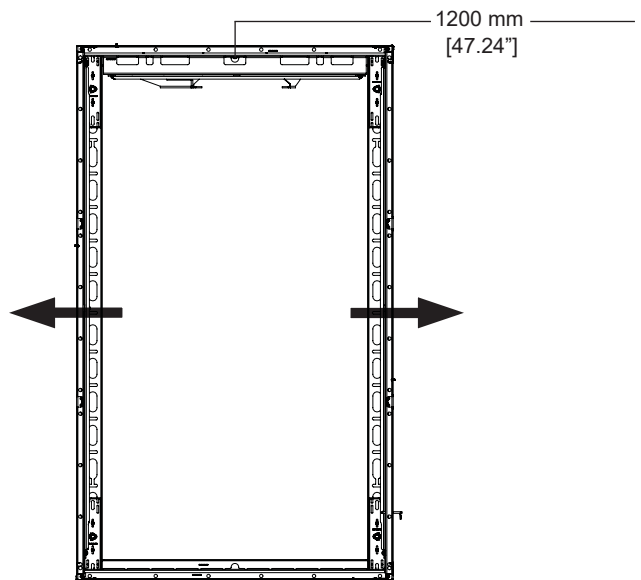

Linear Set Up

11

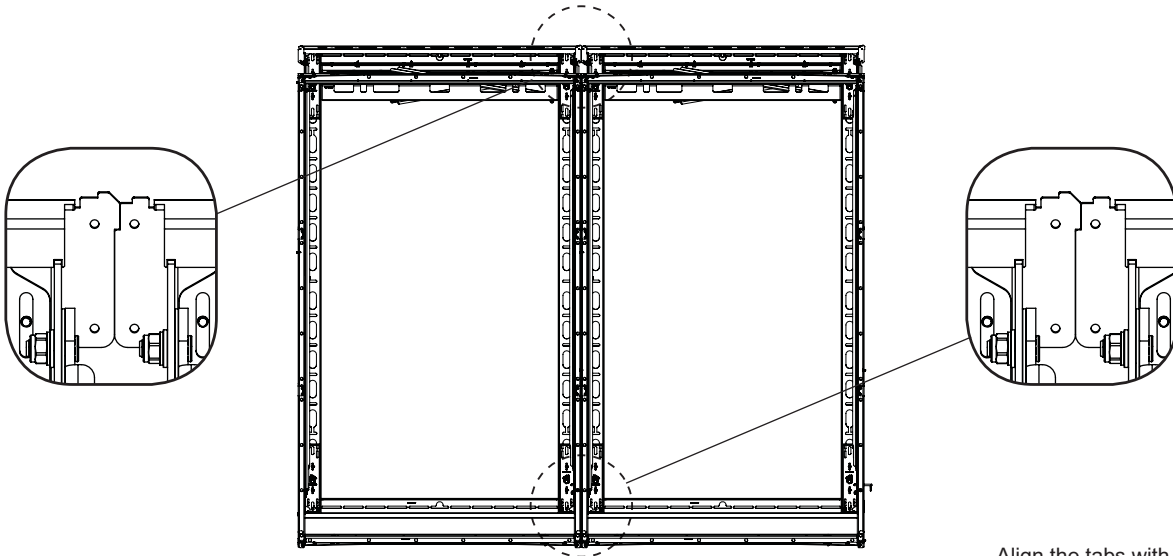

Align the tabs with each other.

12

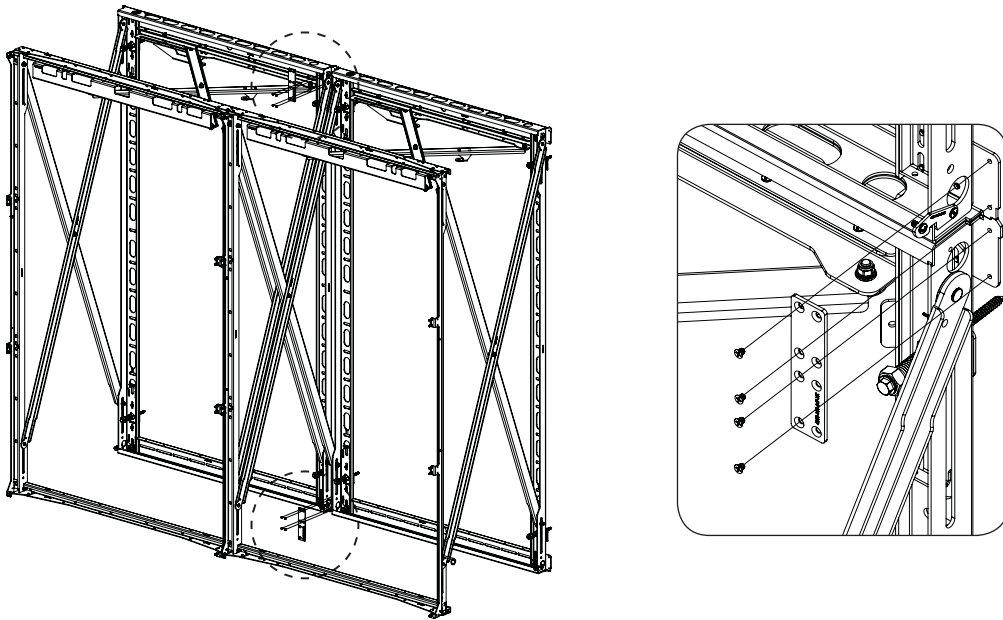

Install the spacer brackets (M) to the mount using eight (8) 6 mm flat head screws (J). Four (4) screws per bracket.

13

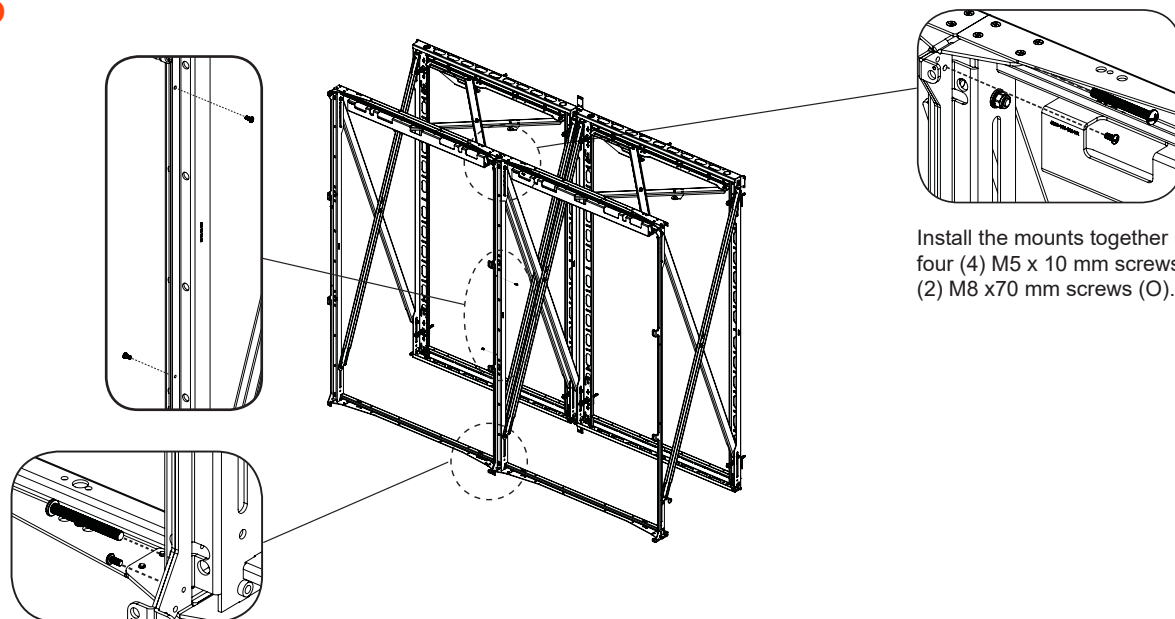

Install the mounts together using four (4) M5 x 10 mm screws (K) and two (2) M8 x70 mm screws (O).

14

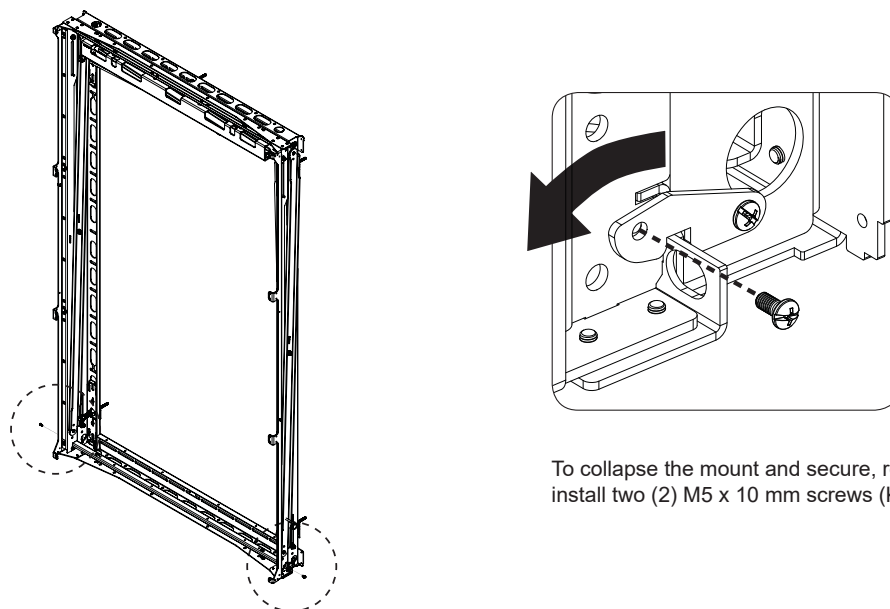

To collapse the mount and secure, remove the push pin than install two (2) M5 x 10 mm screws (K). One screw per latch.

## Adjustments

See steps 6 and 9.

- (GB) Subject to printing errors and technical amendments.
- (NL) Drukfouten en technische wijzigingen voorbehouden.
- (F) Sous réserve de fautes d'impression et de modifications techniques.
- (D) Für Druckfehler übernehmen wir keine Verantwortung. Technische Änderungen vorbehalten.
- (E) Reservados errores de imprenta y sujete a modificaciones.
- (I) Con riserva di modifiche tecniche e di eventuali errori di stampa.
- (P) Reserva-se a ocorrência de gralhas e de modificações técnicas.
- (H) Nyomdahibák és technikai változtatások joga fenntartva.
- (PL) Zastrzeżenie się możliwość występowania błędów drukarskich i zmian technicznych.
- (RUS) Возможны ошибки при печати и технические модификации.

Designed and engineered in the Netherlands  
More information on: [www.vogels.com](http://www.vogels.com)

VOGEL'S PRODUCTS BV, HONDSRUGLAAN 93, 5628 DB EINDHOVEN, THE NETHERLANDS